



US008617919B2

(12) **United States Patent**
Antonenkov

(10) **Patent No.:** **US 8,617,919 B2**
(45) **Date of Patent:** **Dec. 31, 2013**

(54) **ORGANIC LIGHT EMITTING DIODE DISPLAY AND MANUFACTURING METHOD THEREOF**

7,542,199	B1	6/2009	Mayer et al.	
8,125,142	B2 *	2/2012	Sung et al.	313/504
2006/0032586	A1	2/2006	Choi et al.	
2009/0155466	A1	6/2009	Tang	
2012/0025226	A1	2/2012	Oda	

(71) Applicant: **Samsung Display Co., Ltd.**, Yongin-si (KR)

FOREIGN PATENT DOCUMENTS

(72) Inventor: **Dmitry Antonenkov**, Yongin-si (KR)

KR 1998-061775 11/1998

(73) Assignee: **Samsung Display Co., Ltd.**, Yongin-si (KR)

OTHER PUBLICATIONS

(*) Notice: Subject to any disclaimer, the term of this patent is extended or adjusted under 35 U.S.C. 154(b) by 0 days.

Jackman, et al, *Using Elastomeric Membranes as Dry Resists and for Dry Lift-Off*, Langmuir, vol. 15, Mar. 19, 1999, pp. 2973-2984, XP-002700107.

EPO Search Report dated Aug. 9, 2013, for corresponding European Patent application 13164800.8, (10 pages).

(21) Appl. No.: **13/652,002**

* cited by examiner

(22) Filed: **Oct. 15, 2012**

Primary Examiner — Anthony Ho

(65) **Prior Publication Data**

US 2013/0277645 A1 Oct. 24, 2013

(74) Attorney, Agent, or Firm — Christie, Parker & Hale, LLP

(30) **Foreign Application Priority Data**

Apr. 24, 2012 (KR) 10-2012-0042652

(57) **ABSTRACT**

(51) **Int. Cl.**
H01L 51/40 (2006.01)

A manufacturing method of an organic light emitting diode (OLED) display according to an exemplary embodiment includes: forming a thin film transistor panel; forming a deposition mask on the thin film transistor panel by a photolithography process; obliquely spraying an organic material to the deposition mask from a linear deposition source to form an organic emission layer on the thin film transistor panel; and removing the deposition mask by using an adhering film, wherein the deposition mask includes a plurality of deposition walls configured to block the organic material sprayed at an angle that is less than a blocking angle. Accordingly, the deposition mask is formed by the photolithography process such that alignment of the deposition mask is straightforward when manufacturing the organic light emitting diode (OLED) display of a large size.

(52) **U.S. Cl.**
USPC **438/99**; 257/40; 257/E51.001

(58) **Field of Classification Search**
USPC 257/40, E51.001
See application file for complete search history.

(56) **References Cited**

U.S. PATENT DOCUMENTS

5,294,869	A	3/1994	Tang et al.
6,791,258	B2	9/2004	Haase et al.

9 Claims, 18 Drawing Sheets

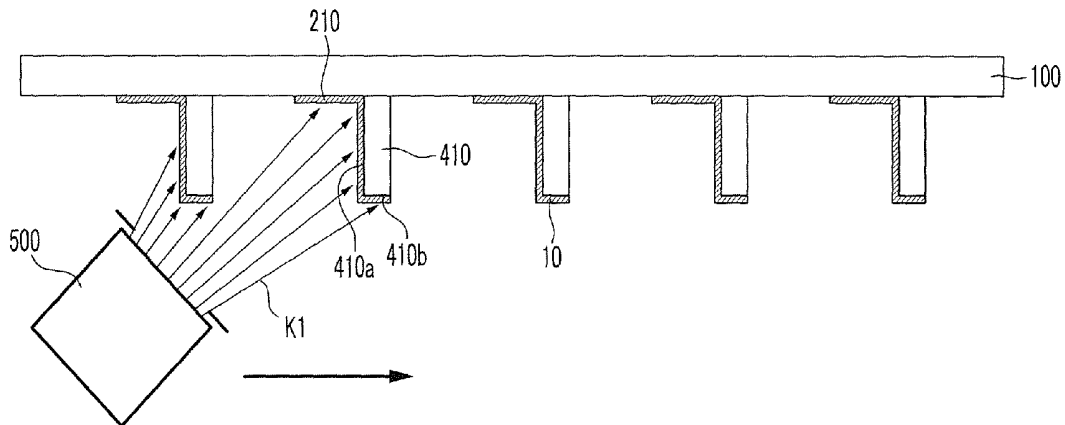

FIG. 1

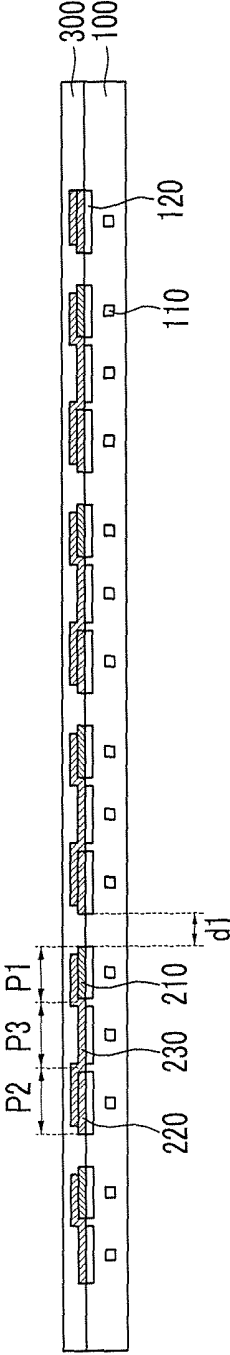

FIG. 2

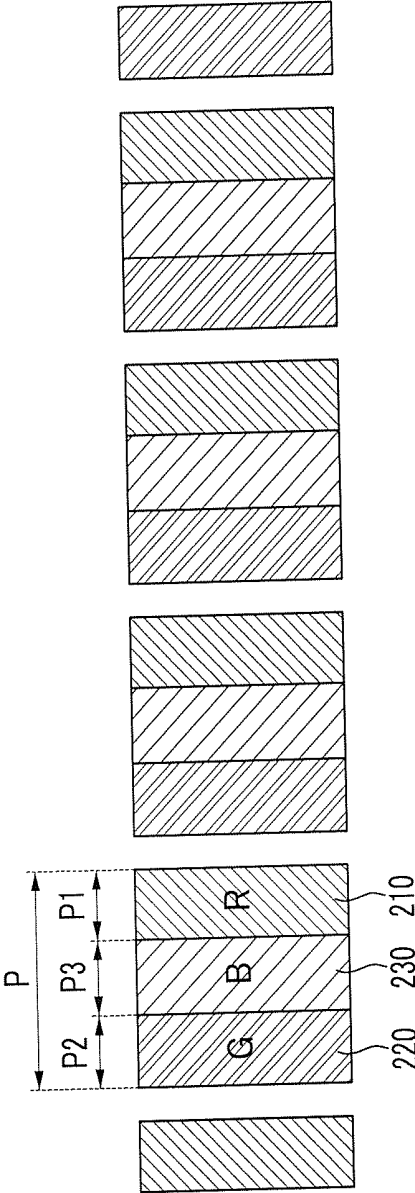

FIG. 3

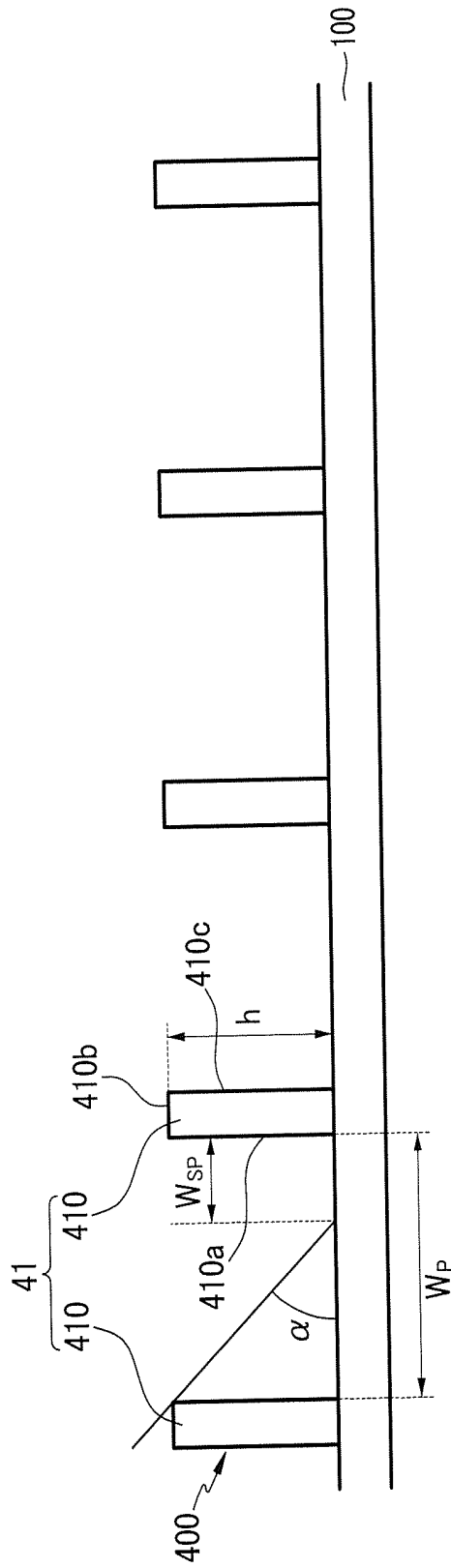

FIG. 4

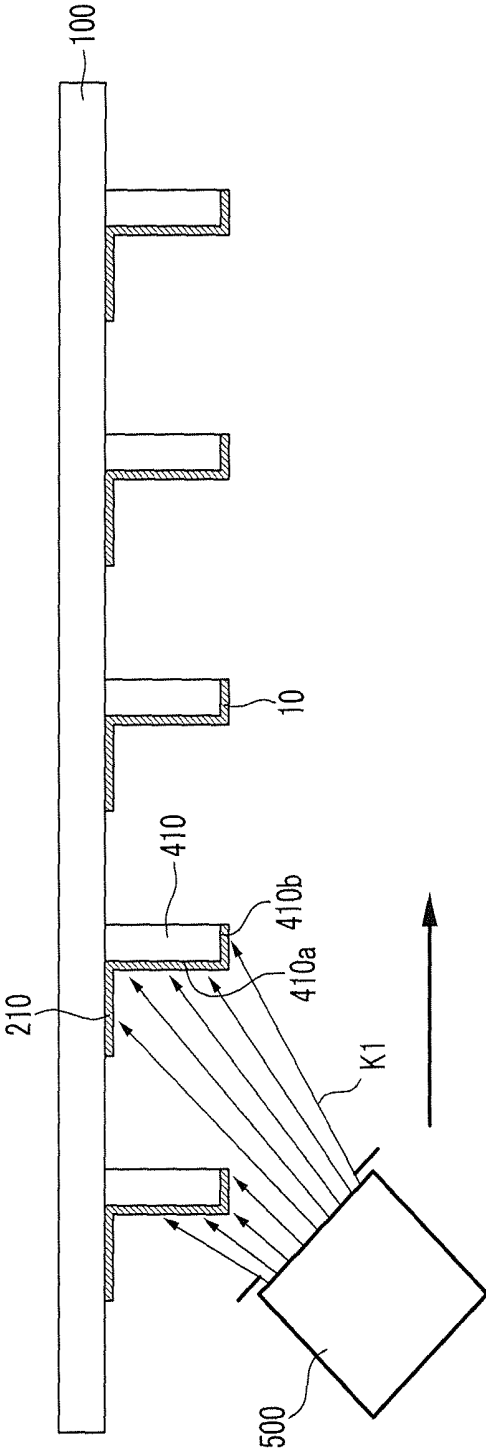

FIG. 5

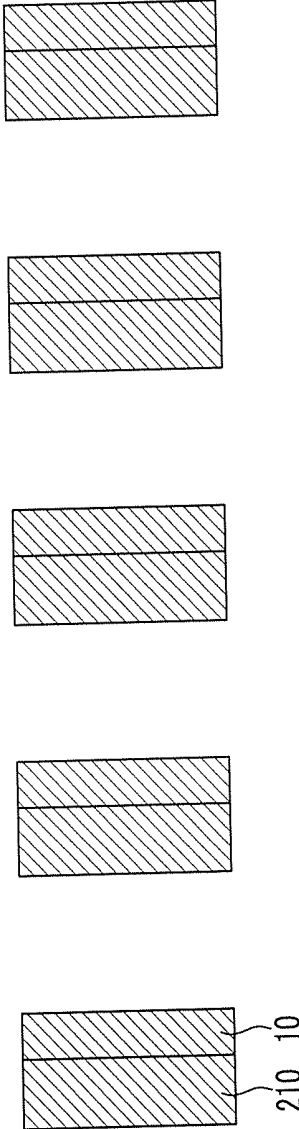

FIG. 6

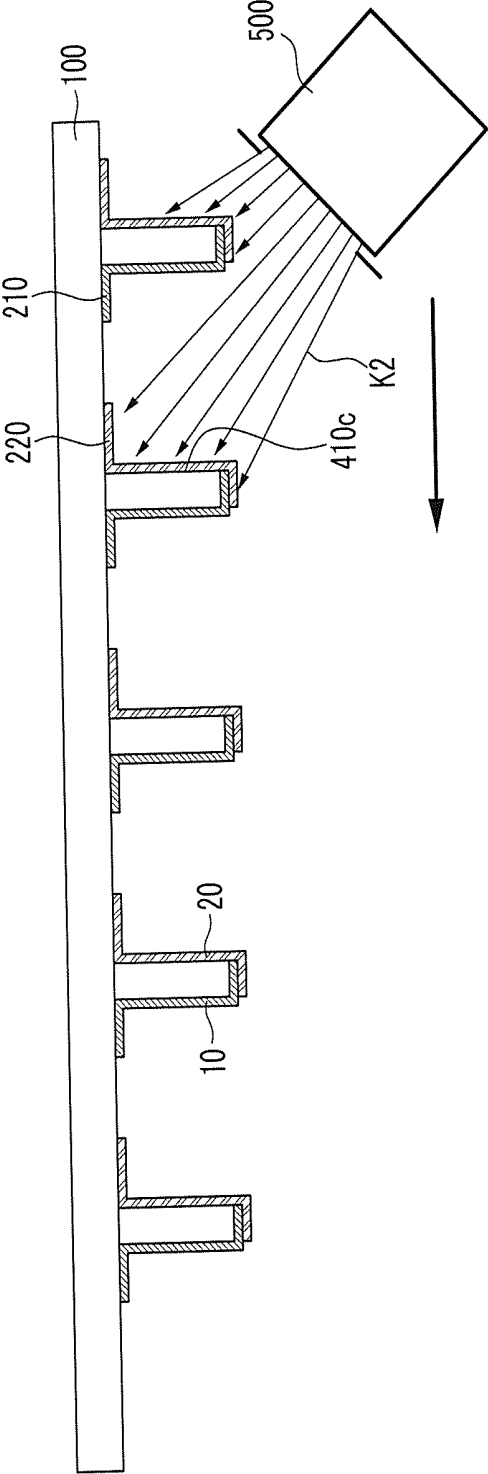

FIG. 7

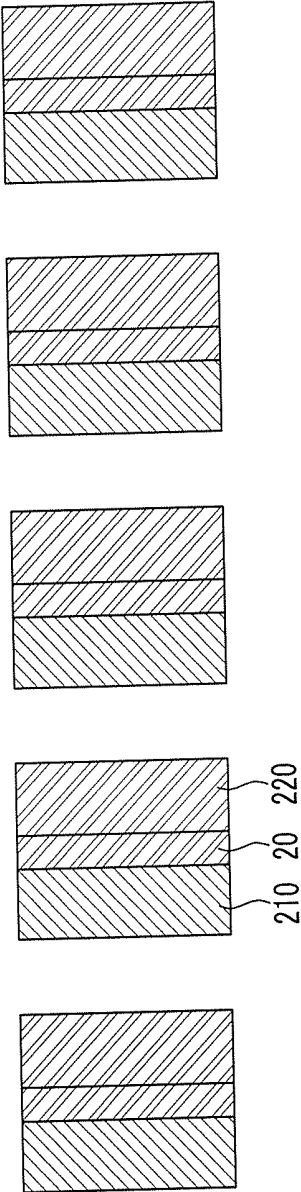

FIG. 8

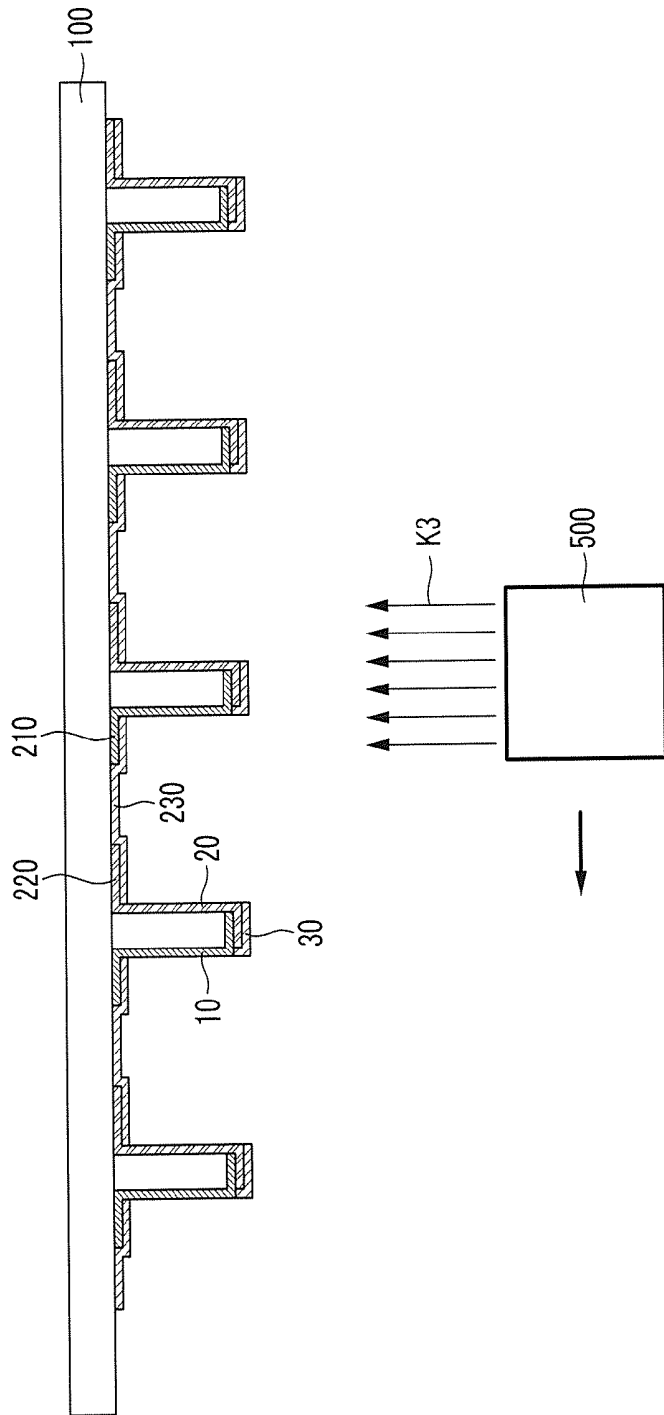

FIG. 9

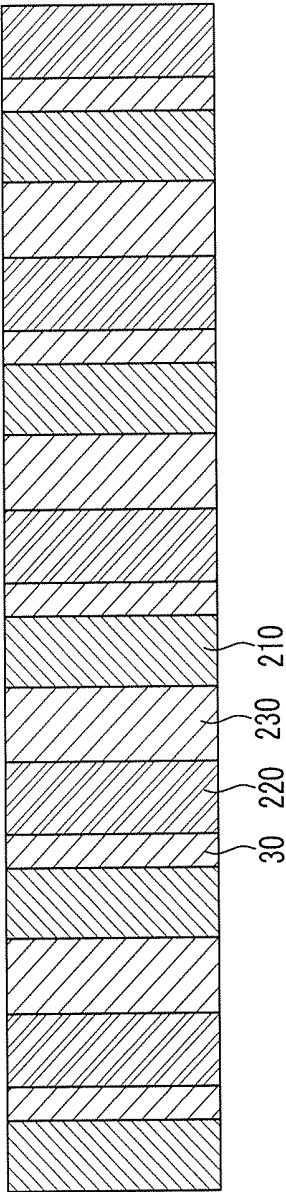

FIG. 10

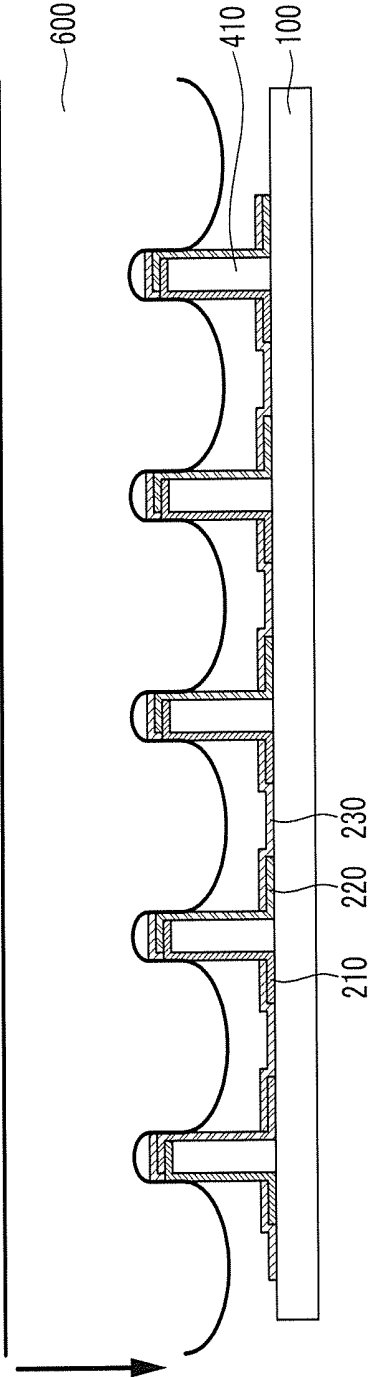

FIG. 11

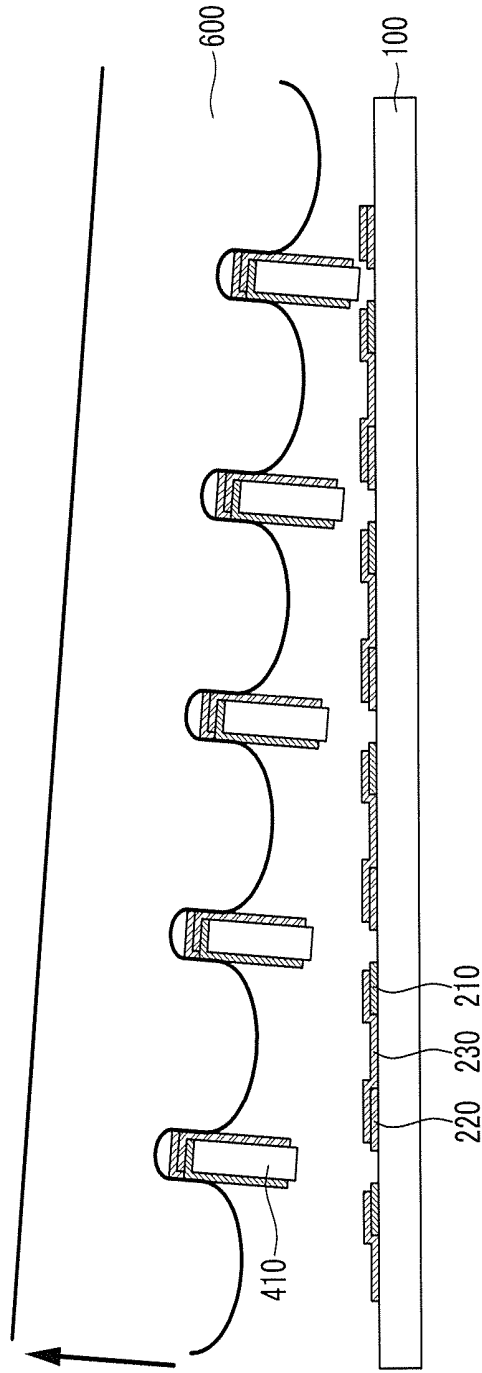

FIG.12

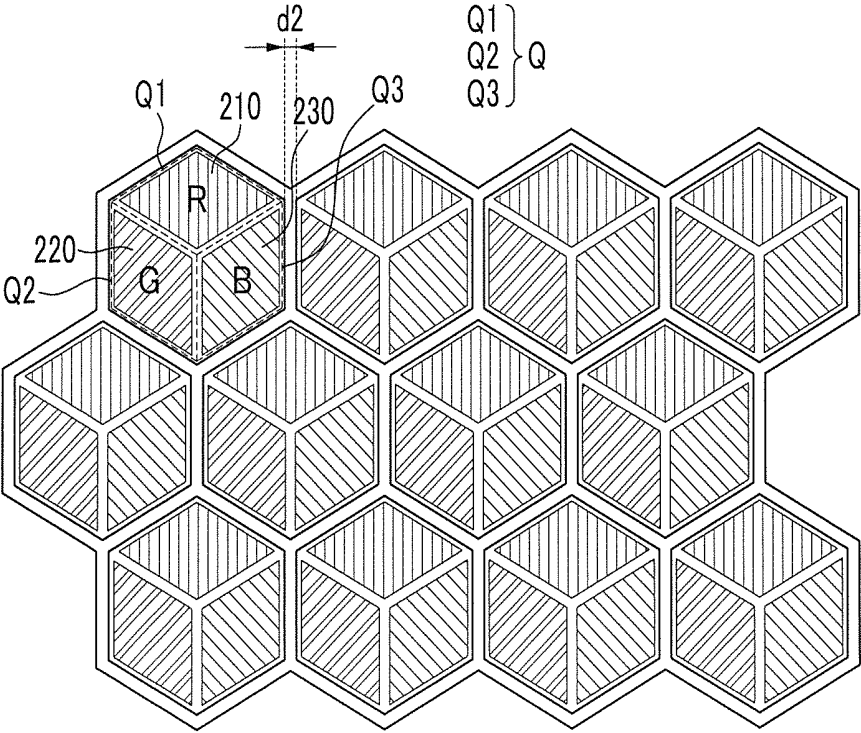

FIG. 13

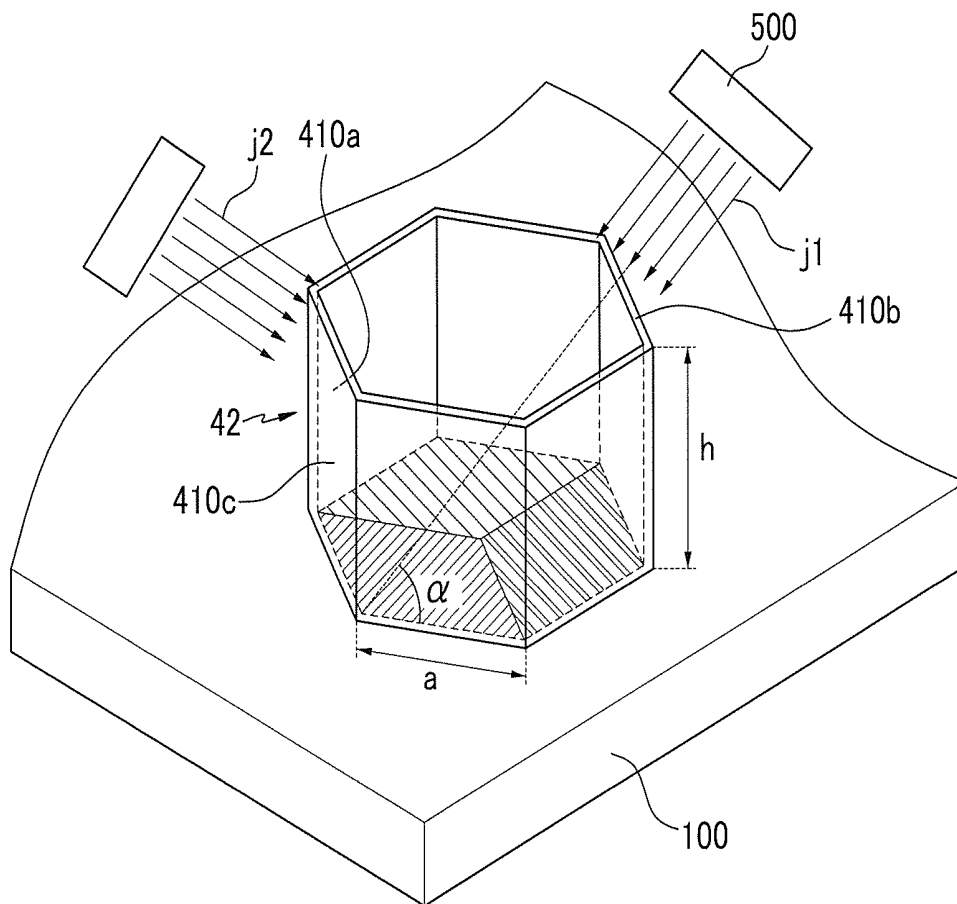

FIG.14

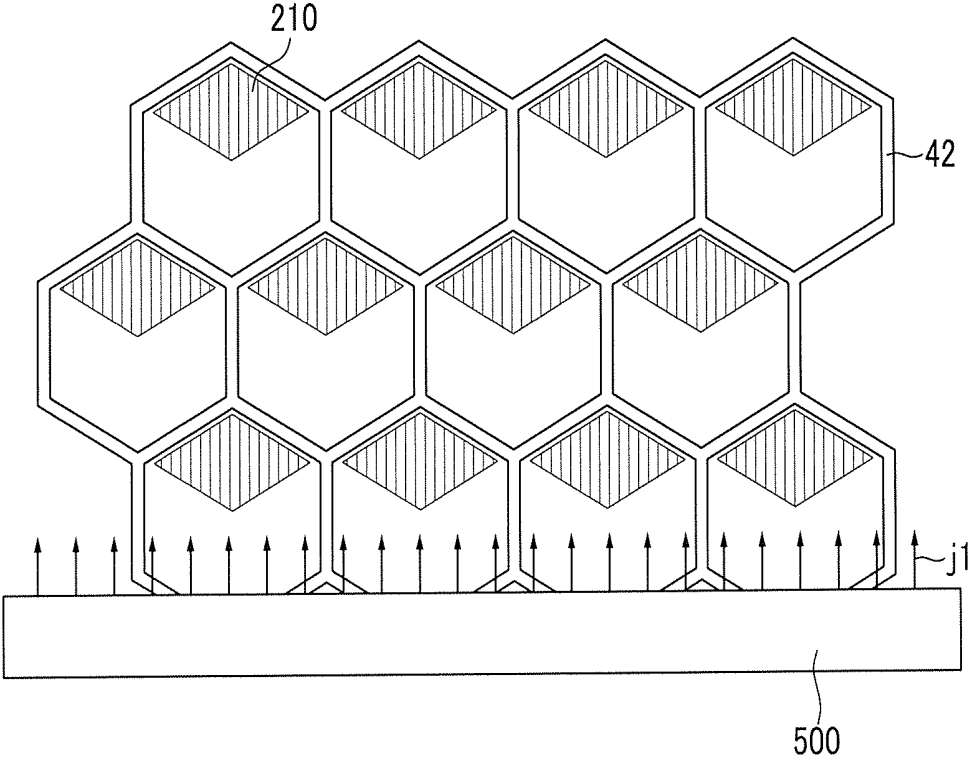

FIG.15

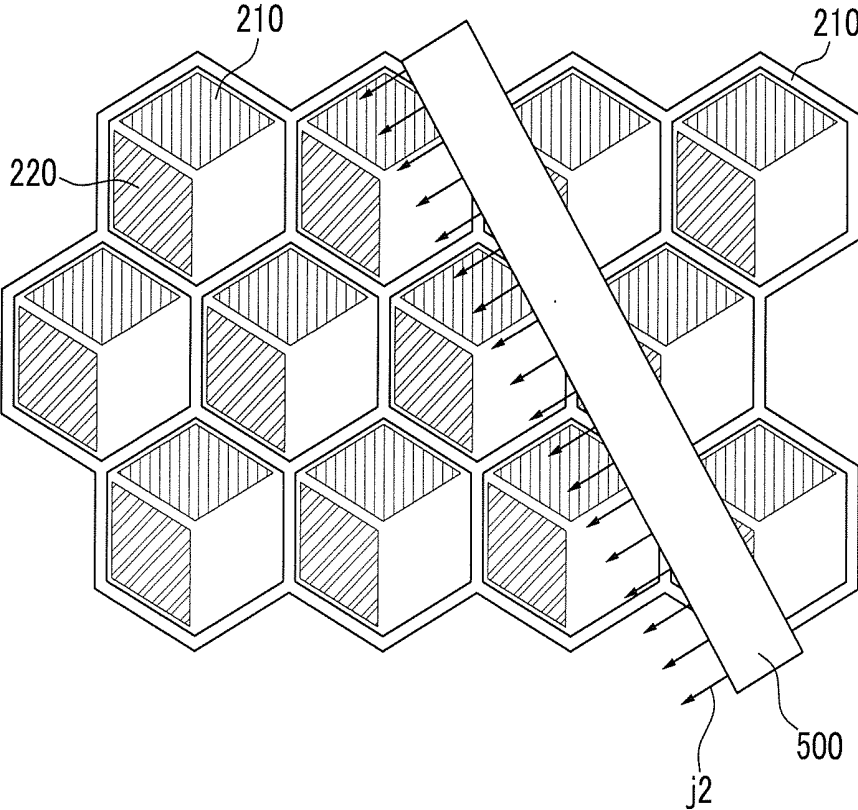

FIG. 16

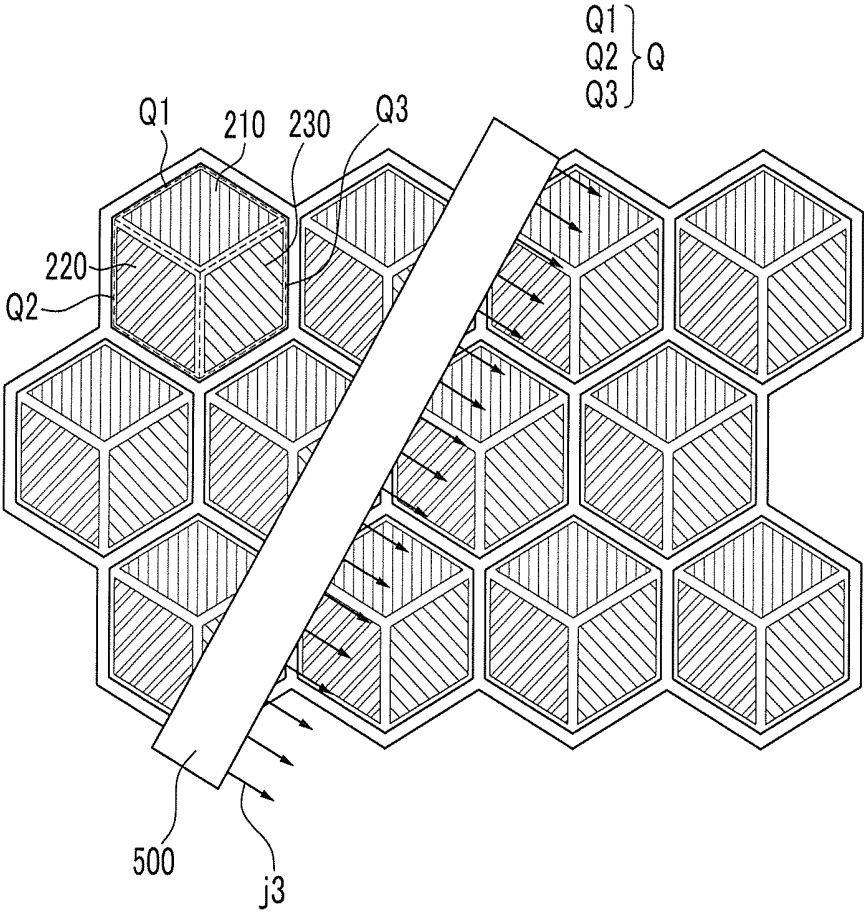

FIG.17

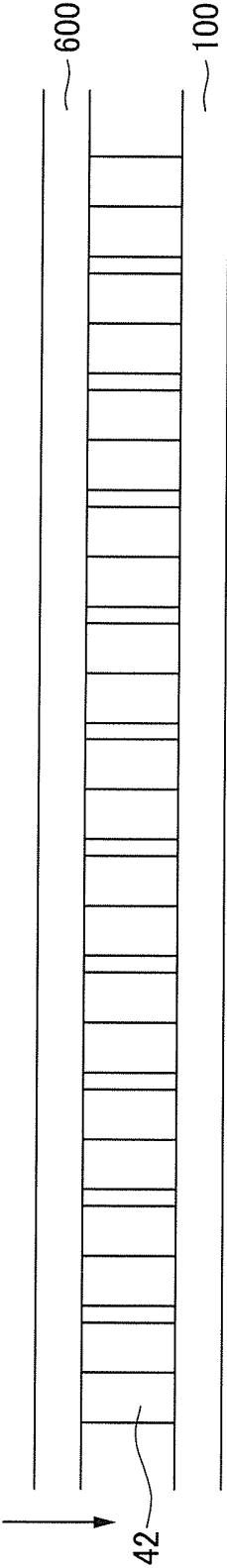
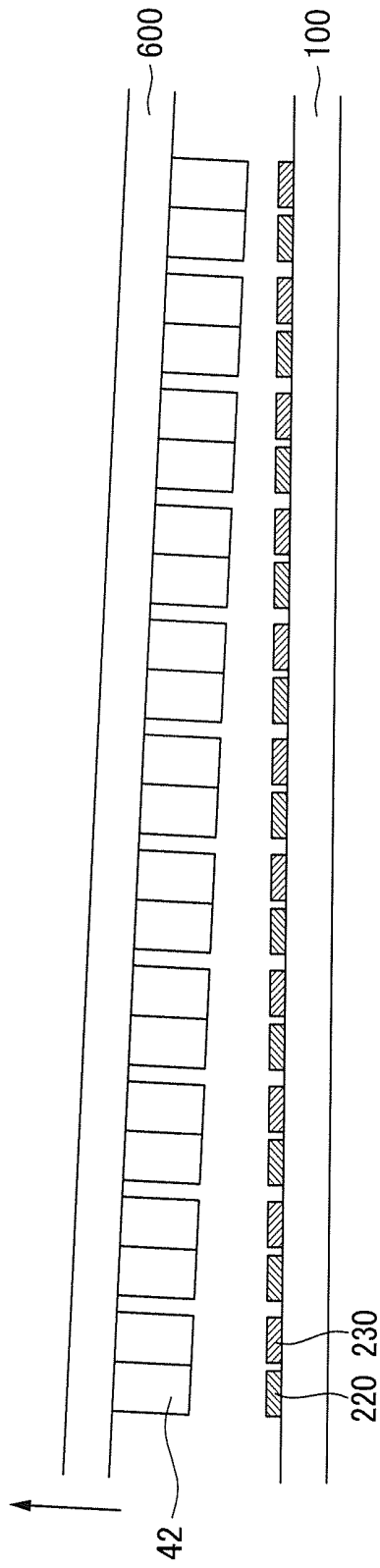

FIG. 18



**ORGANIC LIGHT EMITTING DIODE
DISPLAY AND MANUFACTURING METHOD
THEREOF**

CROSS-REFERENCE TO RELATED
APPLICATION

This application claims priority to and the benefit of Korean Patent Application No. 10-2012-0042652 filed in the Korean Intellectual Property Office on Apr. 24, 2012, the entire content of which is incorporated herein by reference.

BACKGROUND

1. Field

The described technology relates generally to an organic light emitting diode (OLED) display and a manufacturing method thereof.

2. Description of the Related Art

An organic light emitting diode (OLED) display includes organic light emitting diodes each including two electrodes and an organic emission layer disposed therebetween, and electrons injected from one electrode and holes injected from the other electrode are combined in the organic emission layer such that excitons are formed, and light is emitted by the energy generated from the excitons.

To form the organic emission layer, an organic material is deposited on a thin film transistor panel, and to achieve this, a deposition source filled with the organic material is heated to evaporate the organic material. Then, the evaporated organic material is sprayed over the thin film transistor panel. In this case, to deposit the evaporated and sprayed organic material in a pixel area, a deposition mask is used. The deposition mask includes an opening for transmitting the organic material and a blocking portion made of a metal for blocking the organic material.

However, as the size of the organic light emitting diode (OLED) display is increased, it is difficult to align the deposition mask made of the metal with the thin film transistor panel. To solve this problem, a method of obliquely spraying the organic material to the deposition mask from the deposition source has been developed. However, in this case, to compensate for a parallax, a distance between the deposition source and the thin film transistor panel is more than several times the size of the thin film transistor panel. When the size of the thin film transistor panel is several meters or larger, it is difficult to realize this deposition method.

The above information disclosed in this Background section is only for enhancement of understanding of the background of the described technology, and it may contain information that does not form the prior art that is already known in this country to a person of ordinary skill in the art.

SUMMARY

Embodiments of the present invention relate generally to an organic light emitting diode (OLED) display using a deposition mask capable of being applied to a large size organic light emitting diode (OLED) display and being easily aligned, and a manufacturing method thereof.

An organic light emitting diode (OLED) display according to an exemplary embodiment includes: a thin film transistor panel including a plurality of thin film transistors; a first color organic emission layer and a second color organic emission layer formed to be separated from each other on the thin film transistor panel; and a third color organic emission layer covering the thin film transistor panel, the first color organic

emission layer, and the second color organic emission layer, wherein overlapping portions of the first color organic emission layer and the third color organic emission layer correspond to a first subpixel, overlapping portions of the second color organic emission layer and the third color organic emission layer correspond to a second subpixel, and a portion of the third color organic emission layer located between the first color organic emission layer and the second color organic emission layer corresponds to a third subpixel.

The first subpixel, the second subpixel, and the third subpixel may form a quadrangular pixel.

The first color organic emission layer may include a red organic emission layer, the second color organic emission layer may include a green organic emission layer, and the third color organic emission layer may include a blue organic emission layer.

Also, an organic light emitting diode (OLED) display according to another exemplary embodiment includes: a thin film transistor panel including a plurality of thin film transistors; and a first color organic emission layer, a second color organic emission layer, and a third color organic emission layer adjacent to each other and each having a rhombus shape on the thin film transistor panel, wherein the first color organic emission layer, the second color organic emission layer, and the third color organic emission layer respectively correspond to a first subpixel, a second subpixel, and a third subpixel, and the first subpixel, the second subpixel, and the third subpixel form a hexahedral pixel.

A plurality of the hexahedral pixels may be separated from each other and may be arranged in a honeycomb shape.

The first color organic emission layer may include a red organic emission layer, the second color organic emission layer may include a green organic emission layer, and the third color organic emission layer may include a blue organic emission layer.

Also, a manufacturing method of an organic light emitting diode (OLED) display according to an exemplary embodiment includes: forming a thin film transistor panel; forming a deposition mask on the thin film transistor panel by a photolithography process; obliquely spraying an organic material to the deposition mask from a linear deposition source to form an organic emission layer on the thin film transistor panel; and removing the deposition mask by using an adhering film, wherein the deposition mask includes a plurality of deposition walls configured to block the organic material sprayed at an angle that is less than a blocking angle.

The deposition mask may include a parallel deposition wall including two deposition walls that are separated from each other and are substantially parallel to each other.

When a distance between the deposition walls is referred to as W_p , the blocking angle at which the organic material is blocked by the deposition wall is referred to as α , and a deposition length at which the organic material is deposited in the parallel deposition wall is referred to as W_{sp} , a height h of the deposition wall may be defined as follows: $h = (W_p - W_{sp}) \times \tan \alpha$.

The forming of the organic emission layer may include: spraying a first organic material in a first direction to form a first color organic emission layer in the parallel deposition wall; spraying a second organic material in a second direction that is 180 degrees from the first direction, to form a second color organic emission layer in the parallel deposition wall; and spraying a third organic material in a third direction substantially in parallel to a height direction of the deposition wall to form a third color organic emission layer in the parallel deposition wall.

The second color organic emission layer may be separated from the first color organic emission layer.

The deposition mask may include a hexahedral deposition wall forming a hexahedral shape of which six deposition walls are connected to each other.

When a length of the deposition wall is referred to as a and the blocking angle at which the organic material is blocked by the deposition wall is referred to as α , the height h of the deposition wall may be defined by $h=a\tan\alpha$.

The forming of the organic emission layer may include: spraying a first organic material in a first hexahedral direction to form a first color organic emission layer of a rhombus shape in the hexahedral deposition wall; spraying a second organic material in a second hexahedral direction that is 120 degrees from the first hexahedral direction to form a second color organic emission layer of the rhombus shape in the hexahedral deposition wall; and spraying a third organic material in a third hexahedral direction that is 120 degrees from the second hexahedral direction to form a third color organic emission layer of the rhombus shape in the hexahedral deposition wall.

One direction of the first hexahedral direction, the second hexahedral direction, and the third hexahedral direction may be substantially parallel to a direction at which facing edges of the hexahedral deposition wall are connected to each other.

According to exemplary embodiments, the deposition mask is formed by the photolithography process such that the alignment of the deposition mask is straightforward when manufacturing the organic light emitting diode (OLED) display of a large size.

Also, when forming the organic emission layer by using the deposition mask including the hexahedral deposition wall, the blue organic emission layer does not overlap the red organic emission layer and green organic emission layer such that the visibility and the transmittance are improved.

BRIEF DESCRIPTION OF THE DRAWINGS

FIG. 1 is a cross-sectional view of an organic light emitting diode (OLED) display according to a first exemplary embodiment.

FIG. 2 is a top plan view of the organic light emitting diode (OLED) display according to the first exemplary embodiment.

FIG. 3 is a view showing a step of forming a deposition mask as one step of a manufacturing method of an organic light emitting diode (OLED) display according to the first exemplary embodiment.

FIG. 4 is a view showing a step of spraying a first organic material as a following step of FIG. 3.

FIG. 5 is a deposition plan view of the first organic material deposited in FIG. 4.

FIG. 6 is a view showing a step of spraying a second organic material as a following step of FIG. 4.

FIG. 7 is a deposition plan view of the second organic material deposited in FIG. 6.

FIG. 8 is a view showing a step of spraying a third organic material as a following step of FIG. 6.

FIG. 9 is a deposition plan view of the third organic material deposited in FIG. 8.

FIG. 10 is a view showing a step of attaching an adhering film to a deposition mask as a following step of FIG. 8.

FIG. 11 is a view showing a step of separating the deposition mask from a thin film transistor panel by using the adhering film as a following step of FIG. 10.

FIG. 12 is a top plan view of an organic light emitting diode (OLED) display according to a second exemplary embodiment.

FIG. 13 is a perspective view showing a state of spraying an organic material to a deposition mask in a manufacturing method of an organic light emitting diode (OLED) display according to the second exemplary embodiment.

FIG. 14 is a view showing a step of spraying the first organic material in a manufacturing method of an organic light emitting diode (OLED) display according to the second exemplary embodiment.

FIG. 15 is a view showing a step of spraying the second organic material as a following step of FIG. 14.

FIG. 16 is a view showing a step of spraying the third organic material as a following step of FIG. 15.

FIG. 17 is a view showing a step of attaching an adhering film to a deposition mask as a following step of FIG. 16.

FIG. 18 is a view showing a step of separating the deposition mask from the thin film transistor panel by using an adhering film as a following step of FIG. 17.

DETAILED DESCRIPTION

The present invention will be described more fully hereinafter with reference to the accompanying drawings, in which exemplary embodiments of the invention are shown. As those skilled in the art would realize, the described embodiments may be modified in various different ways, all without departing from the spirit or scope of the present invention.

The drawings and description are to be regarded as illustrative in nature and not restrictive. Like reference numerals designate like elements throughout the specification.

In order to clarify layers and regions, thicknesses and sizes thereof are exemplarily illustrated, and thus the present invention is not limited thereto.

Now, an organic light emitting diode (OLED) display according to a first exemplary embodiment will be described with reference to FIG. 1 and FIG. 2.

FIG. 1 is a cross-sectional view of an organic light emitting diode (OLED) display according to the first exemplary embodiment, and FIG. 2 is a top plan view of the organic light emitting diode (OLED) display according to the first exemplary embodiment.

As shown in FIG. 1 and FIG. 2, the organic light emitting diode (OLED) display according to the first exemplary embodiment includes a thin film transistor panel 100 including a plurality of thin film transistors 110, a first color organic emission layer 210 and a second color organic emission layer 220 separated from each other on the thin film transistor panel 100, and a third color organic emission layer 230 covering the thin film transistor panel 100, the first color organic emission layer 210, and the second color organic emission layer 220.

The thin film transistor panel 100 includes a plurality of gate lines for transmitting a scan signal, a plurality of data lines for transmitting a data signal, and a plurality of driving voltage lines for transmitting a driving voltage. The plurality of thin film transistors 110 are connected to the gate lines, the data lines, and the voltage lines. The plurality of thin film transistors 110 include a switching thin film transistor and a driving thin film transistor coupled to a storage capacitor, and an anode 120 of an organic light emitting diode is connected to an output terminal of the driving thin film transistor.

The switching thin film transistor transmits the data signal applied to the data line to the driving thin film transistor in response to the scan signal applied to the gate line, and the driving thin film transistor supplies an output current having a magnitude that is changed according to a voltage difference between the control terminal and the output terminal of the driving thin film transistor.

A cathode **300** connected to a common voltage (V_{ss}) is formed on the third color organic emission layer **230**. The anode **120**, the organic emission layers **210**, **220**, and **230**, and the cathode **300** form a number of organic light emitting diodes (OLED) such that each of the organic light emitting diodes (OLEDs) emits light having an intensity depending on an output current ILD of the driving transistor (Qd), thereby displaying images.

The first color organic emission layer **210** and the third color organic emission layer **230** are deposited, thereby corresponding to a first subpixel P1. The second color organic emission layer **220** and the third color organic emission layer **230** are deposited, thereby corresponding to a second subpixel P2. The third color organic emission layer **230** formed between the first color organic emission layer **210** and the second color organic emission layer **220** corresponds to a third subpixel P3. Also, the first subpixel P1, the second subpixel P2, and the third subpixel P3 form one quadrangular pixel (P), and neighboring quadrangular pixels (P) are disposed to be separated by a set or predetermined distance. A region d1 between the neighboring quadrangular pixels (P) is a region where a deposition mask **400** (shown in FIG. 3) was previously formed.

The first color organic emission layer **210** may be a red organic emission layer, the second color organic emission layer **220** may be a green organic emission layer, and the third color organic emission layer **230** may be a blue organic emission layer. Accordingly, the first subpixel P1 emits a red (R) color, the second subpixel P2 emits a green (G) color, and the third subpixel P3 emits a blue (B) color. This is because visibility of the red color is much better than the blue color in the first subpixel P1 where the red organic emission layer **210** and the blue organic emission layer **230** are deposited, and the visibility of the green color is much better than the blue color in the second subpixel P2 where the green organic emission layer **220** and the blue organic emission layer **230** are deposited.

Next, a manufacturing method of the organic light emitting diode (OLED) display according to the first exemplary embodiment will be described with reference to FIG. 3 to FIG. 11.

FIG. 3 is a view showing a step of forming a deposition mask as one step of a manufacturing method of an organic light emitting diode (OLED) display according to the first exemplary embodiment, FIG. 4 is a view showing a step of spraying a first organic material as a following step of FIG. 3, FIG. 5 is a deposition plan view of the first organic material deposited in FIG. 4, FIG. 6 is a view showing a step of spraying a second organic material as a following step of FIG. 4, FIG. 7 is a deposition plan view of the second organic material deposited in FIG. 6, FIG. 8 is a view showing a step of spraying a third organic material as a following step of FIG. 6, FIG. 9 is a deposition plan view of the third organic material deposited in FIG. 8, FIG. 10 is a view showing a step of adhering an adhering film to a deposition mask as a following step of FIG. 8, and FIG. 11 is a view showing a step of separating a deposition mask from a thin film transistor panel by using the adhering film as a following step of FIG. 10.

As shown in FIG. 3, in the manufacturing method of the organic light emitting diode (OLED) display according to the first exemplary embodiment, a thin film transistor panel **100** is firstly formed. Also, a deposition mask **400** is formed by, for example, a photolithography process on the thin film transistor panel **100**.

The deposition mask **400** includes a plurality of deposition walls **410** configured to block organic materials **10**, **20**, and **30** that are sprayed at an angle of less than a blocking angle (α),

and two deposition walls **410** are separated to be parallel to each other, thereby forming a parallel deposition wall **41** (or cavity). The deposition wall **410** includes an upper surface **410b**, and a first wall **410a** and a second wall **410c** extending from the upper surface **410b** downward.

Here, when a distance between the deposition walls **410** is referred to as W_p , the blocking angle at which the organic materials **10**, **20**, and **30** are blocked by the deposition wall **410** is referred to as α , and a deposition length at which the organic materials **10**, **20**, and **30** are deposited in the parallel deposition wall **41** is referred to as W_{sp} . A height h of the deposition wall **410** is defined by Equation 1 below.

$$h=(W_p-W_{sp})\times\tan\alpha \quad \text{Equation 1}$$

Next, as shown in FIG. 4 and FIG. 5, the first organic material **10** is obliquely sprayed to the deposition mask **400** from a linear deposition source **500** to form the first color organic emission layer **210** on the thin film transistor panel **100**. Here, the linear deposition source **500** is obliquely positioned such that the blocking angle (α) is formed between the spray direction of the first organic material **10** sprayed from the linear deposition source **500** and the surface of the thin film transistor panel **100**. Next, the first organic material **10** is sprayed while the thin film transistor panel **100** is fixed, and the linear deposition source **500** is moved in the horizontal direction, or the first organic material **10** is sprayed while the linear deposition source **500** is fixed and the thin film transistor panel **100** is moved in the horizontal direction.

In FIG. 4, the first organic material **10** is sprayed in the first direction $k1$ as a spray direction of the first organic material **10** to form the first color organic emission layer **210** in the parallel deposition wall **41**. Here, the first organic material **10** is deposited at the first wall **410a** of the deposition wall **410** oppositely facing the first direction $k1$, the upper surface **410b** of the deposition wall **410**, and the first subpixel P1 on the thin film transistor panel **100** adjacent to the first wall **410a**. The first organic material **10** deposited at the first subpixel P1 adjacent to the first wall **410a** becomes the first color organic emission layer **210**.

Next, as shown in FIG. 6 and FIG. 7, the second organic material **20** is sprayed in a second direction $k2$ to form the second color organic emission layer **220** in the parallel deposition wall **41**, and the second direction $k2$ is about 180 degrees from the first direction $k1$. In one embodiment, the second organic material **20** is sprayed while the thin film transistor panel **100** is fixed, and the linear deposition source **500** is moved in the horizontal direction. In another embodiment, while the linear deposition source **500** is fixed, the thin film transistor panel **100** is moved in the horizontal direction.

Here, the second organic material **20** is deposited at the upper surface **410b** of the deposition wall **410**, the second wall **410c** of the deposition wall **410** oppositely facing the second direction $k2$, and the second subpixel P2 on the thin film transistor panel **100** adjacent to the second wall **410c**. The second organic material **20** deposited at the second subpixel P2 adjacent to the second wall **410c** becomes the second color organic emission layer **220**. Therefore, the second color organic emission layer **220** is formed to be separated from the first color organic emission layer **210** by the deposition wall **410**.

Next, as shown in FIG. 8 and FIG. 9, the third organic material **30** is sprayed in a third direction $k3$ parallel to a height direction of the deposition wall **410** to form the third color organic emission layer **230** in the parallel deposition wall **41**. In one embodiment, the third organic material **30** is sprayed while the thin film transistor panel **100** is fixed, and the linear deposition source **500** is moved in the horizontal

direction. In another embodiment, while the linear deposition source **500** is fixed, the thin film transistor panel **100** is moved in the horizontal direction.

Here, the third organic material **30** is deposited at the upper surface **410b** of the deposition wall **410**, the first subpixel **P1**, the second subpixel **P2**, and the third subpixel **P3** on the thin film transistor panel **100**. The third organic material **30** deposited between the first subpixel **P1** and the second subpixel **P2** becomes the third color organic emission layer **230**.

Next, as shown in FIG. 10, an adhering film **600** is adhered to an upper portion of the deposition mask **400**. Also, as shown in FIG. 11, the adhering film **600** is detached upward to concurrently (e.g., simultaneously) separate the deposition mask **400** from the thin film transistor panel **100**. This is because the deposition mask **400** is adhered to the adhering film **600** by the adhesion of the adhering film **600**.

Referring back to FIG. 1, the cathode **300** is formed on the third color organic emission layer **230**, thereby completing the quadrangular pixel (P). As described above, the deposition mask is formed by the photolithography process such that alignment of the deposition mask is straightforward when manufacturing the organic light emitting diode (OLED) display of a large size.

Here, in the first exemplary embodiment, the quadrangular pixel is formed by using the parallel deposition wall. However, in a second exemplary embodiment, a hexahedral pixel may be formed by using a hexahedral deposition wall.

Next, an organic light emitting diode (OLED) display according to the second exemplary embodiment will be described with reference to FIG. 12.

FIG. 12 is a top plan view of an organic light emitting diode (OLED) display according to the second exemplary embodiment.

The second exemplary embodiment shown in FIG. 12 is substantially equivalent to the first exemplary embodiment shown in FIG. 1 and FIG. 2 except for the hexahedral pixel such that the repeated description is omitted.

As shown in FIG. 12, the organic light emitting diode (OLED) display according to the second exemplary embodiment includes a thin film transistor panel **100** (shown in FIG. 13) including a plurality of thin film transistors, and a first color organic emission layer **210**, a second color organic emission layer **220**, and a third color organic emission layer **230** adjacent to each other on the thin film transistor panel **100**. Each of the first, second, and third color organic emission layers **210**, **220**, and **230** having a rhombus shape.

The first color organic emission layer **210**, the second color organic emission layer **220**, and the third color organic emission layer **230** respectively correspond to a first subpixel **Q1**, a second subpixel **Q2**, and a third subpixel **Q3**. Also, the first subpixel **Q1**, the second subpixel **Q2**, and the third subpixel **Q3** form one hexahedral pixel (Q), and adjacent hexahedral pixels (Q) are separated by a set or predetermined distance, thereby forming a honeycomb shape. A region **d2** between the adjacent hexahedral pixels (Q) is a region where a deposition mask **400** was previously formed.

In one embodiment, the first color organic emission layer **210** may be the red organic emission layer, the second color organic emission layer **220** may be the green organic emission layer, and the third color organic emission layer **230** may be the blue organic emission layer. Accordingly, the first subpixel **Q1** emits the red (R) color light, the second subpixel **Q2** emits the green (G) color light, and the third subpixel **Q3** emits the blue (B) color light. In this case, differently from the first exemplary embodiment, the blue organic emission layer **230** does not overlap the red organic emission layer **210** and

the green organic emission layer **220** such that the visibility and the transmittance are improved.

Next, the manufacturing method of the organic light emitting diode (OLED) display according to the second exemplary embodiment will be described with reference to FIG. 13 to FIG. 18.

FIG. 13 is a perspective view showing a state of spraying organic materials to a deposition mask in a manufacturing method of an organic light emitting diode (OLED) display according to the second exemplary embodiment, FIG. 14 is a view showing a step of spraying the first organic material in a manufacturing method of an organic light emitting diode (OLED) display according to the second exemplary embodiment, FIG. 15 is a view showing a step of spraying the second organic material as a following step of FIG. 14, FIG. 16 is a view showing a step of spraying the third organic material as a following step of FIG. 15, FIG. 17 is a view showing a step of adhering film to a deposition mask as a following step of FIG. 16, and FIG. 18 is a view showing a step of separating a deposition mask from a thin film transistor panel by using an adhering film as a following step of FIG. 17.

Referring to FIG. 13, in the manufacturing method of the organic light emitting diode (OLED) display according to the second exemplary embodiment, the thin film transistor panel **100** is firstly formed. Also, the deposition mask **400** may be formed by the photolithography process on the thin film transistor panel **100**.

The deposition mask **400** includes a plurality of deposition walls **410** for blocking the organic materials **10**, **20**, and **30** that are sprayed at less than the blocking angle (α). Six deposition walls **410** are connected to each other, thereby forming a hexahedral deposition wall **42** in the hexahedral shape. The deposition wall **410** includes an upper surface **410b**, and a first wall **410a** and a second wall **410c** extending from the upper surface **410b** downward.

When the length of the deposition wall **410** is referred to as a , and the blocking angle at which the organic materials **10**, **20**, and **30** are blocked by the deposition wall **410** is referred to as α , the height h of the deposition wall **410** is defined by Equation 2 as follows.

$$h = a \tan \alpha \quad \text{Equation 2}$$

Next, as shown in FIG. 13 and FIG. 14, the first organic material **10** is obliquely sprayed from the linear deposition source **500** to the deposition mask **400** to form the first color organic emission layer **210** on the thin film transistor panel **100**. In this embodiment, the linear deposition source **500** is obliquely positioned such that the blocking angle (α) is formed between the spray direction of the first organic material **10** sprayed from the linear deposition source **500** and the surface of the thin film transistor panel **100**.

Referring to FIG. 13 and FIG. 14, the first organic material **10** is sprayed in a first hexahedral direction $j1$ to form the first color organic emission layer **210** in the hexahedral deposition wall **42**. The first color organic emission layer **210** of the rhombus shape is formed in the inner portion of the hexahedral deposition wall **42** that is not blocked by the hexahedral deposition wall **42**. The first hexahedral direction $j1$ is substantially parallel to a direction connecting facing edges of the hexahedral deposition walls **42**.

Next, as shown in FIG. 13 and FIG. 15, the second organic material **20** is sprayed in a second hexahedral direction $j2$ that is 120 degrees from the first hexahedral direction $j1$, to form the second color organic emission layer **220** of the rhombus shape in the hexahedral deposition wall **42**.

Next, as shown in FIG. 13 and FIG. 16, the third organic material **30** is sprayed in a third hexahedral direction $j3$ that is

120 degrees from the second hexahedral direction j_2 , to form the third color organic emission layer 230 of the rhombus shape in the hexahedral deposition wall 42.

Next, as shown in FIG. 17, the adhering film 600 is adhered to the upper portion of the deposition mask 400 including the hexahedral deposition walls 42. Next, as shown in FIG. 18, an upward force is applied to detach the adhering film 600, and the deposition mask 400 is concurrently (e.g., simultaneously) separated from the thin film transistor panel 100. This is because the deposition mask 400 is attached to the adhering film 600 by the adhesion of the adhering film 600.

Accordingly, as shown in FIG. 12, the hexahedral pixels (Q) separated from each other are completed.

As described above, the deposition mask is formed by the photolithography process such that the alignment of the deposition mask is straightforward when manufacturing the organic light emitting diode (OLED) display of a large size.

Also, in one embodiment, the organic emission layer is formed by using the deposition mask including the hexahedral deposition wall such that the blue organic emission layer does not overlap the red organic emission layer and the green organic emission layer, thereby improving the visibility and the transmittance.

While the present invention has been described in connection with what is presently considered to be practical exemplary embodiments, it is to be understood that the invention is not limited to the disclosed embodiments, but, on the contrary, is intended to cover various modifications and equivalent arrangements included within the spirit and scope of the appended claims, and their equivalents.

Description of Some Symbols

100: thin film transistor panel	210: first color organic emission layer
220: second color organic emission layer	230: third color organic emission layer
400: deposition mask	410: deposition wall
500: linear deposition source	600: adhering film

What is claimed is:

1. A method for manufacturing an organic light emitting diode (OLED) display, the method comprising:
 - forming a thin film transistor panel;
 - forming a deposition mask on the thin film transistor panel by a photolithography process;
 - obliquely spraying an organic material to the deposition mask from a linear deposition source to form an organic emission layer on the thin film transistor panel; and
 - removing the deposition mask by using an adhering film, wherein the deposition mask comprises a plurality of deposition walls configured to block the organic material sprayed at an angle that is less than a blocking angle.
2. The method of claim 1, wherein the plurality of deposition walls comprises a parallel deposition wall comprising two deposition walls that are separated from each other and are substantially parallel to each other.

3. The method of claim 2, wherein when a distance between the deposition walls is referred to as W_p , the blocking angle at which the organic material is blocked by the deposition wall is referred to as α , and a deposition length at which the organic material is deposited in the parallel deposition wall is referred to as W_{sp} , a height h of the deposition wall is defined as follows:

$$h = (W_p - W_{sp}) \times \tan \alpha.$$

4. The method of claim 2, wherein the forming of the organic emission layer comprises:
 - spraying a first organic material in a first direction to form a first color organic emission layer in the parallel deposition wall;
 - spraying a second organic material in a second direction that is 180 degrees from the first direction, to form a second color organic emission layer in the parallel deposition wall; and
 - spraying a third organic material in a third direction substantially in parallel to a height direction of the deposition wall, to form a third color organic emission layer in the parallel deposition wall.

5. The method of claim 4, wherein the second color organic emission layer is separated from the first color organic emission layer.

6. The method of claim 1, wherein the plurality of deposition walls comprises a hexahedral deposition wall forming a hexahedral shape of which six deposition walls are connected to each other.

7. The method of claim 6, wherein when a length of the deposition wall is referred to as a and the blocking angle at which the organic material is blocked by the deposition wall is referred to as α , the height h of the deposition wall is defined by

$$h = a \times \tan \alpha.$$

8. The method of claim 6, wherein the forming of the organic emission layer comprises:
 - spraying a first organic material in a first hexahedral direction to form a first color organic emission layer of a rhombus shape in the hexahedral deposition wall;
 - spraying a second organic material in a second hexahedral direction that is 120 degrees from the first hexahedral direction, to form a second color organic emission layer of the rhombus shape in the hexahedral deposition wall; and
 - spraying a third organic material in a third hexahedral direction that is 120 degrees from the second hexahedral direction, to form a third color organic emission layer of the rhombus shape in the hexahedral deposition wall.

9. The method of claim 8, wherein one direction of the first hexahedral direction, the second hexahedral direction, and the third hexahedral direction is substantially parallel to a direction at which facing edges of the hexahedral deposition wall are connected to each other.

* * * * *

专利名称(译)	有机发光二极管显示器及其制造方法		
公开(公告)号	US8617919	公开(公告)日	2013-12-31
申请号	US13/652002	申请日	2012-10-15
[标]申请(专利权)人(译)	三星显示有限公司		
申请(专利权)人(译)	三星DISPLAY CO. , LTD.		
当前申请(专利权)人(译)	三星DISPLAY CO. , LTD.		
[标]发明人	ANTONENKOV DMITRY		
发明人	ANTONENKOV, DMITRY		
IPC分类号	H01L51/40		
CPC分类号	H01L51/504 H01L27/3218 H01L51/5278 H01L51/0016 H01L51/56 H01L51/0003 H01L51/0011		
审查员(译)	HO , ANTHONY		
优先权	1020120042652 2012-04-24 KR		
其他公开文献	US20130277645A1		
外部链接	Espacenet USPTO		

摘要(译)

根据示例性实施例的有机发光二极管 (OLED) 显示器的制造方法包括：形成薄膜晶体管面板;通过光刻工艺在薄膜晶体管面板上形成沉积掩模;从线性沉积源向沉积掩模倾斜喷射有机材料，以在薄膜晶体管面板上形成有机发射层;通过使用粘附膜去除沉积掩模，其中沉积掩模包括多个沉积壁，所述多个沉积壁构造成阻挡以小于阻挡角度的角度喷射的有机材料。因此，通过光刻工艺形成沉积掩模，使得在制造大尺寸的有机发光二极管 (OLED) 显示器时，沉积掩模的对准是直截了当的。

